



Company presentation



Desind was founded in 2013 by Vasilis Vasiliou after working for about 10 years in the architectural building systems sector. He worked at Alumil (www.alumil.com) as Product Manager in the R&D department and established a new design process based on the project management principles.



At Desind we have worked in various projects that helped us expand our knowledge and expertise.

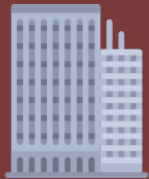

Architectural building systems and accessories
Opening , sliding , curtain wall , lift-slide , folding , balustrade



Special machine for industrial use

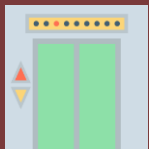

Elevator parts

SERVICES

Our services include:

- **Product development**
- **Mechanical design**
- **Prototyping**
- **R&D services**
- **Technical documentation**

Product development

- Industrial design
- Aluminium building systems
- Accessories and fittings
- Consumer products

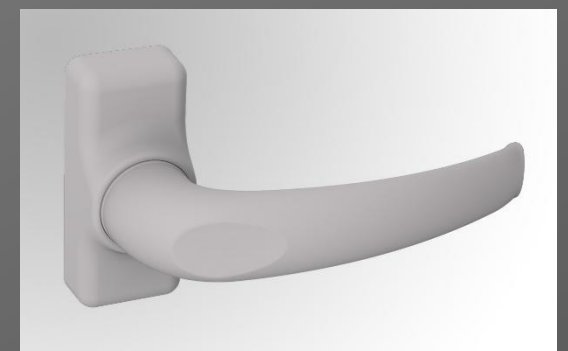
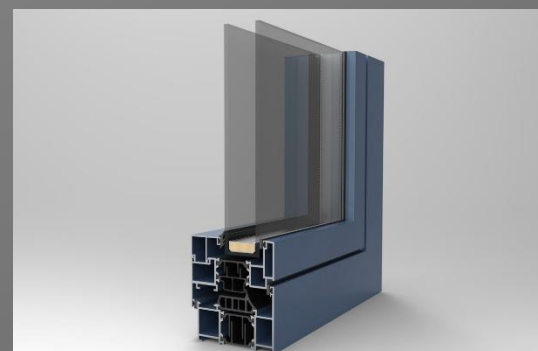
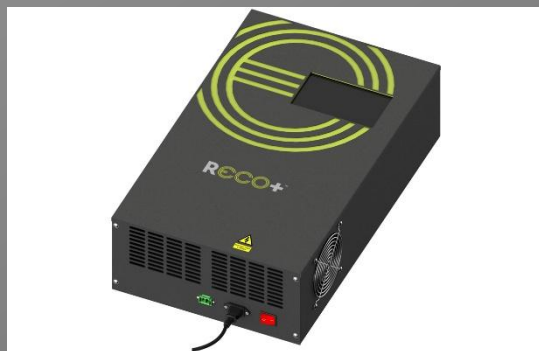
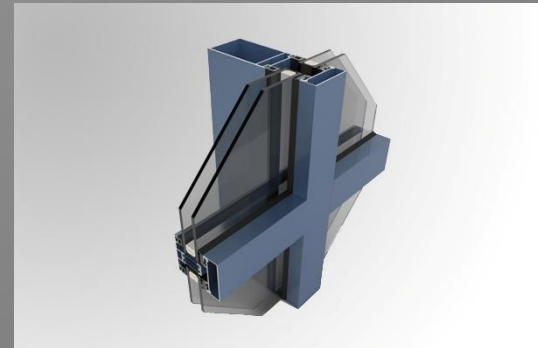
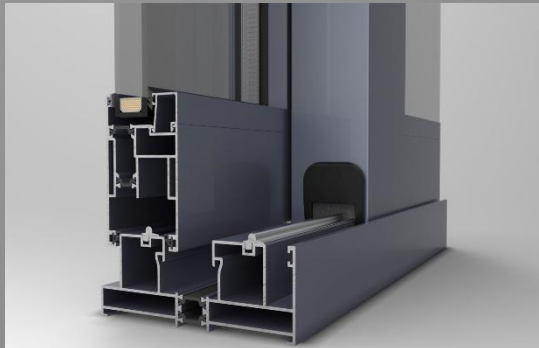
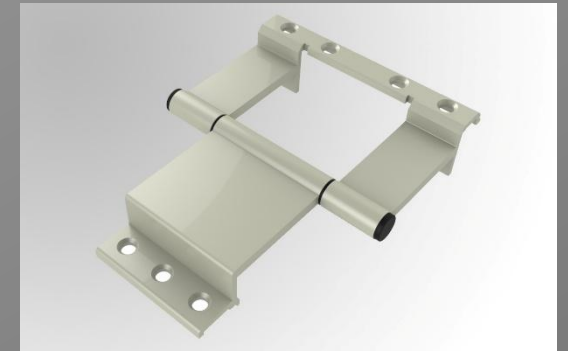

Mechanical design

- Machine design
- FEA
- Accessories and parts
- Simulations

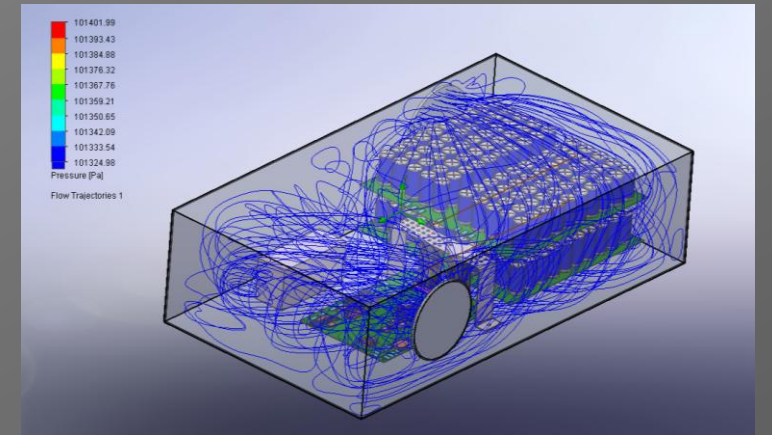
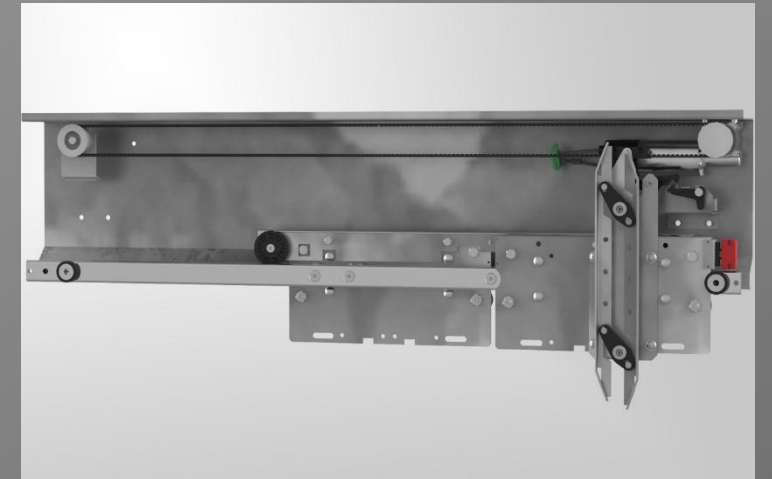
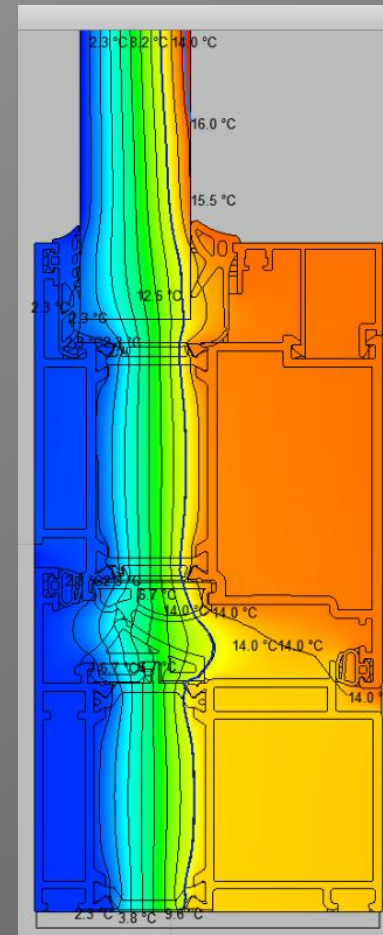
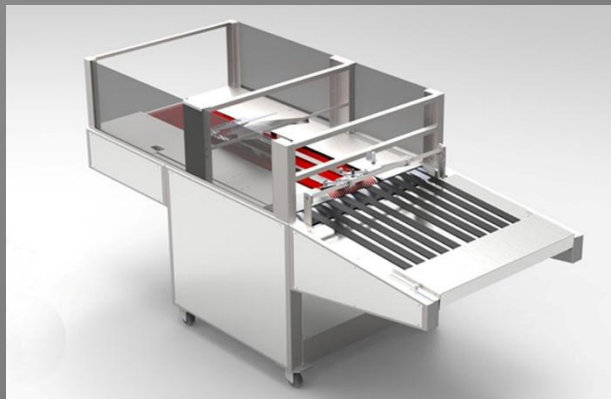

Prototyping

- 3D printing
- CNC milling
- Vacuum casting
- Small productions



R&D services

- Consulting
- CAD automations
- Market research
- Innovation management



Technical documentation

- Technical catalogs
- Product catalogs
- Assembly instructions

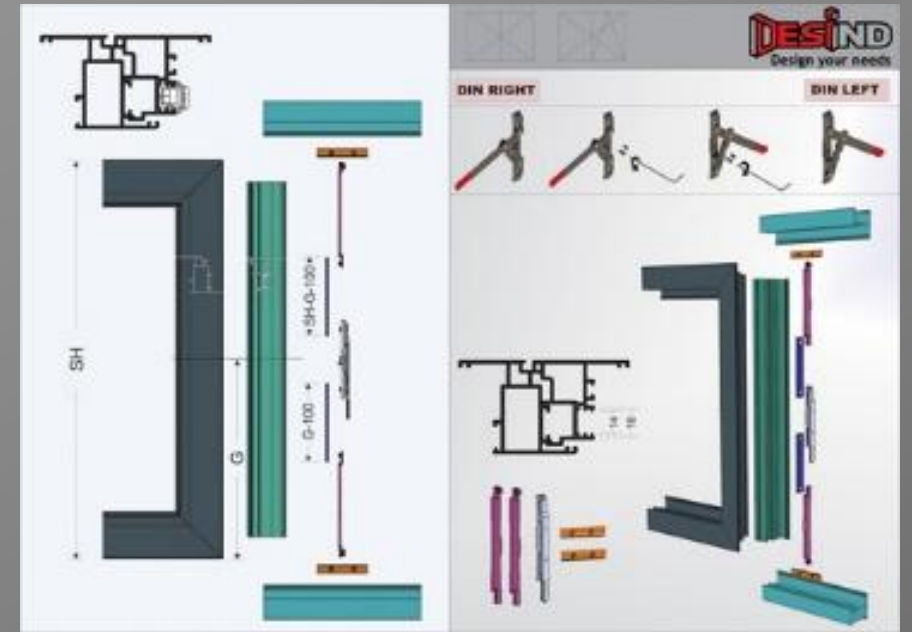

How we work

- Project management
- Design for Manufacture
- Innovative solutions
- Quality
- Sustainability



Define

- Background
- Set your aims for the project intervention
- Develop objectives to achieve the aims
- Identify a high level timescale (key stages and milestones of the project intervention)

Design it

- Plan to achieve the project objectives
 - Estimate the time you require
 - Prepare intervention timetable and cycle of events
 - Identify constraints & dependencies
- Select appropriate actions to add value to the working relationship
- Prepare to track & capture detail of events

Do it

- Plan events and activities including Preparation time pre-event
- Carry out activities
- Reflection/Action time post event
- Capture & record data
- Provide feedback / timely responses
- Review progress against plan

Deliver it

- Test the service/product - gain appropriate feedback
- Measure the outcomes against the project objectives
- Refine the aims and build into next cycle of events
- Learn from the project and build into practice

Contact us

Phone: +30 2311 11 22 65

e-mail: info@desind.gr

www.desind.gr

